



METRO-PAK COMPACTOR SYSTEMS



Refuse and Linen Chutes Refuse and Linen Chute Intake Doors

SALES • SERVICE • INSTALLATION

21 Quine St, Cranford, NJ 07016
info@metropolitancompactor.com
www.metropolitancompactor.com

Phone: 908-653-0169
Fax: 908-653-0167

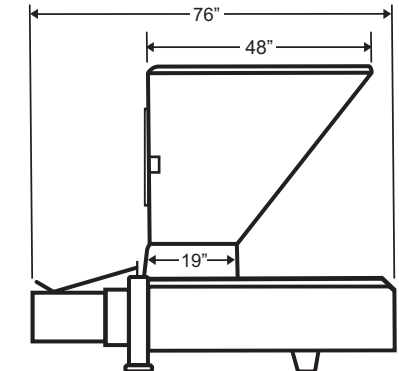
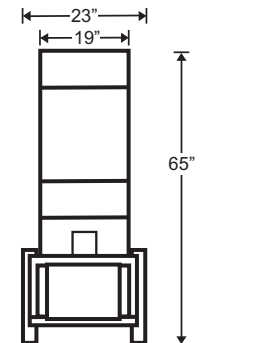

SPECIFICATIONS

GENERAL DESCRIPTION

The Model No. **MC-4000, METRO PAK** Compactor is a hydraulically operated horizontal extruder-type unit. Compacted refuse can be extruded into continuous plastic tubing, individual plastic bags or reusable 2 cubic yard containers.

GENERAL FEATURES INCLUDE:

1. Compactor body, ram extrusion nozzle and compaction chamber are integrally welded of high abrasion resistant steel.
2. Hydraulic power unit designed for 3000 psi operation and operated at 2200/2400 psi.
3. Electric motor is 5 HP, 1750 RPM, 208/220/440 volts, 14.7 amps, 3 phase, 60 cycles, 4 wire, includes thermal overload protection, and magnetic starter. Optional single phase motor also available.
4. System is activated by an automatic sensor with compaction ram starting from fully retracted position. Sensor is a photoelectric switch utilizing an LED circuit.
5. Unit is designed to handle normal household refuse having an approximate density of 125 lb cubic yard. Capacity is 1500 lb/hour.
6. Unit is factory assembled, wired and tested prior to shipment
7. Safety features include full container switch, emergency stop switch, hopper door switch and manual shut-off gate.
8. Ram face of 206 sq. in. with throat charging area of 361 sq. in. (19" x 19") and hopper charging area of 912 sq. in. (19" x 48").

MECHANICAL FEATURES INCLUDE:

1. Compactor body – minimum 3/8" thickness including replaceable wear plate.
2. Compaction ram – minimum 3/8" thickness with 1" thick ram face plate.

3. Hopper – 11 gauge with 1/4" thick impact plate. Hopper access door of 11 gauge (15" x 20").
4. Ram force of 58,920 lb at 3000 psi hydraulic system pressure. Ram pressure, ram force divided by ram area, equals 286 lb/square inch.

ELECTRICAL FEATURES INCLUDE:

1. Motor 208/220/440 volts, 3 phase, 60 cycles, 1750 RPM
2. Control circuit (fused): 115 volts
3. All wiring in liquid-tight (3/8") flexible metal conduit.
4. Control panel includes 5 amp fuse for control circuit, with power OFF-ON switch and reverse switch.

HYDRAULIC FEATURES INCLUDE:

1. Hydraulic cylinder – 5" diameter bore and 24" stroke.
2. Hydraulic hoses – 3/8" (SAE 100 R-8) 4000 psi working pressure.
3. Hydraulic pump, vane pump. 5.2 GPM.
4. Directional control valve/manifold: two coil, neutral center (NEMA 13) with manifold block and automatic pressure relief valve.
5. All components have minimum 4 to 1 safety factor for burst pressure.
6. Cycle time: 28-32 seconds.
7. Compacting ratio: approximately 5 to 1.
8. Hydraulic reservoir: 12 gallons within 10 micron suction strainer, breather cap, and oil level indicator.

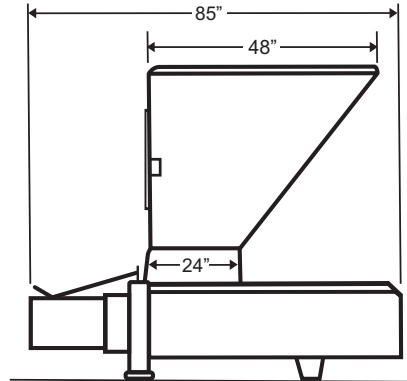
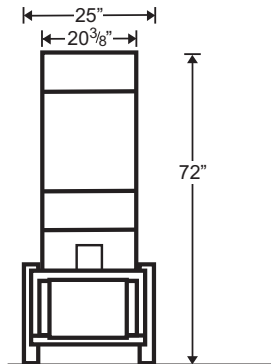

SPECIFICATIONS

GENERAL DESCRIPTION

The Model No. MC-4500, **METRO PAK** Compactor is a hydraulically operated horizontal extruder-type unit. Compacted refuse can be extruded into continuous plastic tubing, individual plastic bags or reusable 2 cubic yard containers.

GENERAL FEATURES INCLUDE:

1. Compactor body, ram extrusion nozzle and compaction chamber are integrally welded of high abrasion resistant steel.
2. Hydraulic power unit designed for 3000 psi operation and operated at 2200/2400 psi.
3. Electric motor is 5 HP, 1750 RPM, 208/220/440 volts, 14.7 amps, 3 phase, 60 cycles, 4 wire, includes thermal overload protection, and magnetic starter. Optional single phase motor also available.
4. System is activated by an automatic sensor with compaction ram starting from fully retracted position. Sensor is a photoelectric switch utilizing an LED circuit.
5. Unit is designed to handle normal household refuse having an approximate density of 125 lb cubic yard. Capacity is 2500 lb/hour.
6. Unit is factory assembled, wired and tested prior to shipment
7. Safety features include full container switch, emergency stop switch, hopper door switch and manual shut-off gate.
8. Ram face of 250 sq. in. with throat charging area of 480 sq. in. (20" x 24") and hopper charging area of 960 sq. in. (20" x 48").

MECHANICAL FEATURES INCLUDE:

1. Compactor body – minimum. 3/8" thickness including replaceable wear plate.
2. Compaction ram – minimum. 3/8" thickness with 1" thick ram face plate.

3. Hopper – 11 gauge with 1/4" thick impact plate. Hopper access door of 11 gauge (15" x 20").
4. Ram force of 58,920 lb at 3000 psi hydraulic system pressure. Ram pressure, ram force divided by ram area, equals 236 lb square inch.

ELECTRICAL FEATURES INCLUDE:

1. Motor 208/220/440 volts, 3 phase, 60 cycles, 1750 RPM
2. Control circuit (fused): 115 volts
3. All wiring in liquid-tight (3/8") flexible metal conduit.
4. Control panel includes 5 amp fuse for control circuit, with power OFF-ON switch and reverse switch.

HYDRAULIC FEATURES INCLUDE:

1. Hydraulic cylinder – 5" diameter bore and 28" stroke.
2. Hydraulic hoses – 3/8" (SAE 100 R-8) 4000 psi working pressure.
3. Hydraulic pump, vane pump. 5.2 GPM.
4. Directional control valve/manifold: two coil, neutral center (NEMA 13) with manifold block and automatic pressure relief valve.
5. All components have minimum 4 to 1 safety factor for burst pressure.
6. Cycle time: 28-32 seconds.
7. Compacting ratio: approximately 5 to 1.
8. Hydraulic reservoir: 12 gallons within 10 micron suction strainer, breather cap, and oil level indicator.



METROPOLITAN

Compactor Service Corporation



Trash Chutes Doors

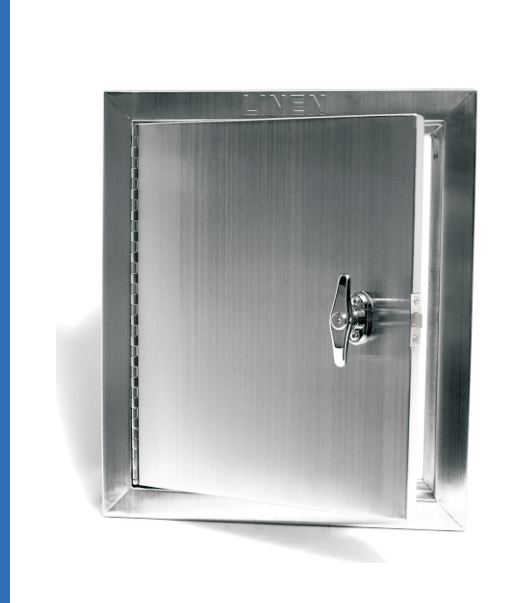

Linen Chutes Doors

Trash and linen chute intake doors, *hopper doors*, are hand operated, self-closing with a locking Tee-handle. Specifications include: 22 gauge stainless steel, UL B label rated – 1½ hour 250°, 30 minutes temperature rise. Refuse doors are bottom hinged and are available in standard sizes – 12"x15" and 15"x18" – and custom sizes. Linen doors are side hinged.

Multi-storied trash and linen chutes are fully factory assembled with all joints welded or lapped. Chutes have a flush interior with no protruding bolts, rivets or clips. Chutes are constructed of 16-gauge aluminized-steel, available in various diameters – 24" being the industry standard. Intakes are located on each floor as desired and provisions for a sprinkler system and hot water flushing/cleaning system are included.

General

Metropolitan Compactor Service Corporation specializes in the sales and service of refuse compactors, trash and linen chutes and trash and linen chute doors. We are expert at the installation of new equipment, replacement of exhausted equipment and service of existing equipment.

Service

Our prompt and professional service staff has extensive experience with all brands of compactors and doors. We perform service calls for the repair of compactors, repair and replacement of chute doors, repairs to chutes, and routine compactor maintenance to keep your equipment in proper, safe operating condition. Our mechanics are considered the best in the industry and will get your equipment repaired quickly with as little inconvenience as possible.

SALES • SERVICE • INSTALLATION

21 Quine St, Cranford, NJ 07016
info@metropolitancompactor.com
www.metropolitancompactor.com

Phone: 908-653-0169
Fax: 908-653-0167